

TECHNICAL MANUAL

GENERAL SUPPORT MAINTENANCE MANUAL

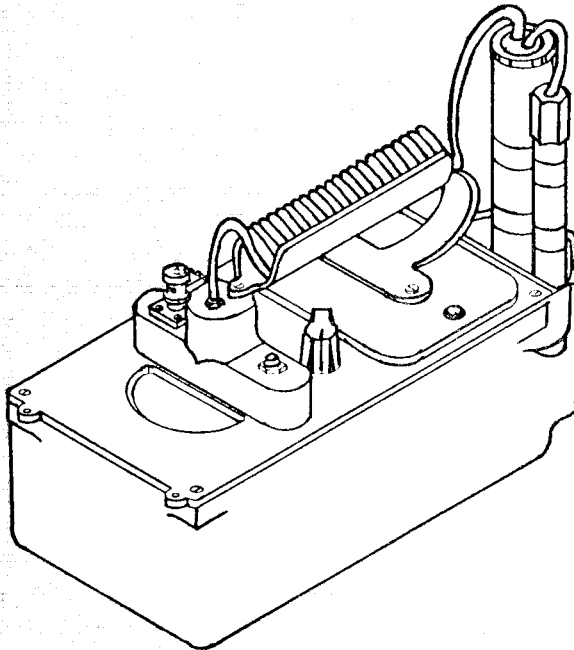

EQUIPMENT DESCRIPTION
& DATA
PAGE 1-2

PRINCIPLES OF OPERATION
PAGE 1-3

TROUBLESHOOTING
PROCEDURES
PAGE 2-1

DISASSEMBLY/ASSEMBLY
PROCEDURES ON
RADIAC UNITS
PAGE 3-1

DISASSEMBLY/ASSEMBLY
PROCEDURES OF
DETECTOR PROBE
PAGE 3-8

ADJUSTMENTS
PAGE 3-11

RADIAC SETS

AN/PDR-27J (NSN 6665-00-543-1435)

AN/PDR-27L (NSN 6665-00-856-3456)

AN/PDR-27Q (NSN 6665-00-017-8903)

APPENDIX
A-1

HEADQUARTERS, DEPARTMENT OF THE ARMY

10 JUNE 1981

WARNING

RADIATION HAZARD - KRYPTON 85

**Test Sample used in this equipment is RADIOACTIVE
and contains 5 millicuries of KRYPTON 85.**



Do Not:

- Handle the test sample by the active (colored) end.
- Place the test sample next to your skin.

Do:

- Keep the test sample in the case when not in use.
- Handle only as necessary.
- Handle test sample only by flat end (handle).
- Assure that the test sample is securely attached to the radiac set case with the chain provided.

WARNING

HIGH VOLTAGE (900 VOLTS) IS Presented in this equipment.

DON'T TAKE CHANCES

Be careful not to come in contact with high voltage or power connections in this equipment. Turn off the power before making any connections or doing any work inside the equipment.

Prevent Eye Injury - Wear protective eye wear while performing any soldering.



5

SAFETY STEPS TO FOLLOW IF SOMEONE IS THE VICTIM OF ELECTRICAL SHOCK

1

DO NOT TRY TO PULL OR GRAB THE INDIVIDUAL

2

IF POSSIBLE, TURN OFF THE ELECTRICAL POWER

3

IF YOU CANNOT TURN OFF THE ELECTRICAL POWER, PULL, PUSH, OR LIFT THE PERSON TO SAFETY USING A WOODEN POLE OR A ROPE OR SOME OTHER INSULATING MATERIAL

4

SEND FOR HELP AS SOON AS POSSIBLE

5

AFTER THE INJURED PERSON IS FREE OF CONTACT WITH THE SOURCE OF ELECTRICAL SHOCK, MOVE THE PERSON A SHORT DISTANCE AWAY AND IMMEDIATELY START ARTIFICIAL RESUSCITATION

GENERAL SUPPORT MAINTENANCE MANUAL
FOR
RADIAC SETS

AN/PDR-27J (NSN 6665-00-543-1435)
AN/PDR-27L (NSN 6665-00-856-3456)
AN/PDR-27Q (NSN 6665-00-017-8903)

REPORTING OF ERRORS AND RECOMMENDING IMPROVEMENTS

You can improve this manual. Please tell us if you find any mistakes or if you know a way to improve the procedures. Mail your letter, DA Form 2028 (Recommended Changes to Publications and Blank Form), or DA Form 2028-2 located in the back of this manual directly to: Commander, US Army Communications and Electronics Material Readiness Command, ATTN: DRSEL-ME-MQ, Fort Monmouth, New Jersey 07703. A reply will be sent to you.

TABLE OF CONTENTS

		Paragraph	Page
CHAPTER 1.	INTRODUCTION		
Section I.	General Information		1-1
	Scope	1-1	1-1
	Forms and Records	1-2	1-1
	Indexes of Publications	1-3	1-1
	Reporting Equipment Improvement Recommendations (EIR's).	1-4	1-1
Section II.	Equipment Description and Data		1-2
	Equipment Description.	1-5	1-2
	Tabulated Data	1-6	1-2
	Calibration	1-7	1-2
	Differences Between Models	1-8	1-2
Section III.	Principles of Operation		1-3
	Radiac Set Block Diagram Analysis.	1-9	1-3
	Radiac Set Circuit Analysis	1-10	1-7

*This manual together with TM 11-6665-209-10, dated 12 March 1981 and TM 11-6665-209-20, dated 12 March 1981, supersedes TM 11-6665-209-15, 2 September 1960, including all changes in its entirety.

TABLE OF CONTENTS (continued)

	Paragraph	Page
CHAPTER 2.	TROUBLESHOOTING	
	General Instructions	2-1 2-1
	Organization of Troubleshooting Procedures.	2-2 2-1
	Repair Parts, Test Equipment and Tools	2-3 2-3
	Waveforms and Test Points	2-4 2-3
	Troubleshooting Procedures	2-5 2-4
CHAPTER 3	GENERAL SUPPORT REPAIR PROCEDURES AND ADJUSTMENTS	3-1
	General Parts Replacement Techniques	3-1 3-1
	Disassembly/Assembly Procedures of Radic Set AN/PDR-27J	3-2 3-1
	Disassembly/Assembly Procedures of Detector DT-196/PDR-27J	3-3 3-8
	Adjustments	3-4 3-11
APPENDIX A	REFERENCES	A-1

CHAPTER 1 INTRODUCTION

Section I. GENERAL INFORMATION

1-1. SCOPE

a. This manual contains a description of general support (GS) maintenance for Radiac Set AN/PDR-27. Manual includes instructions for the GS maintenance of the AN/PDR-27J, AN/PDR-27L and AN/PDR-27Q. Manual includes troubleshooting, testing, and adjustment procedures; also lists the test equipment and tools required for the maintenance of the radiac set.

b. The official nomenclature followed by (*) represents Radiac Sets AN/PDR-27J, AN/PDR-27L and AN/PDR-27Q.

c. The radiac sets detect and measure gamma and beta radiation together or gamma radiation alone.

d. The complete technical manual for this equipment includes TM 11-6665-209-10, and TM 11-6665-209-20.

1-2. MAINTENANCE FORMS, RECORDS AND REPORTS

Department of the Army forms and procedures used for equipment maintenance will be those prescribed by TM 38-750, The Army Maintenance Management Systems (TAMMS).

1-3. INDEXES OF PUBLICATIONS

a. DA Pam 310-4. Refer to the latest issue of DA Pam. 310-4 to determine whether there are new editions, changes, Modification Work Orders (MWO'S) or additional publications pertaining to the equipment.

1-4. REPORTING EQUIPMENT IMPROVEMENT RECOMMENDATIONS (EIR's)

EIR's can and must be submitted by anyone who is aware of an unsatisfactory condition with the equipment design or use. It is not necessary to show a new design or list a better way to perform a procedure, just simply tell why the design is unfavorable or why a procedure is difficult. EIR's may be submitted on SF368 (Quality Deficiency Report). Mail directly to Commander, U.S. Army Communications and Electronics Material Readiness Command, ATTN: DRSEL-ME-MQ, Fort Monmouth, New Jersey 07703. A reply will be furnished to you.

Section II. EQUIPMENT DESCRIPTION AND DATA

1-5. EQUIPMENT DESCRIPTION

Refer to TM 11-6665-209-10, paragraphs 1-6 through 1-10 for a complete description of the radiac set.

1-6. TABULATED DATA

- a. Power requirements: Six type BA-30; 1½ volt batteries.
- b. Ranges: Four sensitivity ranges; 0.5, 5, 50 and 500 milliroentgens per hour.
- c. Detectors: Geiger-Mueller (G-M) tubes type JAN-5979 and JAN-5980.
- d. Type of indication: Direct reading and aural.
- e. Dimensions (cased):

(1) Height	10-½ inches
(2) Width	8 inches
(3) Length	19-¾ inches

- f. Weight (cased): 33 pounds

1-7. CALIBRATION

Calibration requirements for the radiac sets are located in TB 43-180, (Calibration Requirement for the Maintenance of Army Material).

1-8. DIFFERENCES BETWEEN MODELS

The only differences between models are the components. Table 1-1 lists the differences between components used in all AN/PDR-27(*) models. These components are illustrated on the schematic diagram. (Figure 1-1)

TABLE 1-1

COMPONENT	AN/PDR-27J IM-141/PDR-27J	AN/PDR-27L IM-173/PDR-27L	AN/PDR-27Q IM-195/PDR-27Q
CR101	4U1	1N485B	4U1
CR102	4U1	1N485B	4U1
CR103	4U1	1N485B	4U1
CR106	1N69	1N933	1N69
CR107	2T1	1N1626A	2T1
Q101	2N64	2N526	2N1305*
Q102	2N64	2N526	2N1305*
Q103	2N460	2N331	2N1305
Q104	2N64	2N526	2N1305
Q105	2N35	2N335	2N1304
R102	1K ohms	2.2K ohms	1K ohms
R111	680K ohms	100K ohms	680K ohms*

*Transistors Q101 and Q102 of AN/PDR-27Q, manufactured by Industrial Electronics Hardware Corp., on Contract No. N0BSR87564, changed from 2N1305 to 2N526;

*resistor R111 same model was changed from 680K ohms to 100K ohms.

Section III. PRINCIPLES OF OPERATION

1-9. RADIAC SET BLOCK DIAGRAM ANALYSIS

Radiac Sets AN/PDR-27(*) are compact units when discussed consisting of nine functional blocks which are described in Figure 1-2.

A Six 1½ volt dry cells in series furnish all the power necessary for operation of the equipment and, at 25°C (77°F), can power it for approximately 40 hours of continuous operation.

B The power supply circuit converts the 9 volt DC power from the battery into regulated +700 volts DC, which is fed to the G-M tubes in the detector circuit. The high-voltage circuit uses a corona-discharge regulator tube **V102** to keep the output voltage constant.

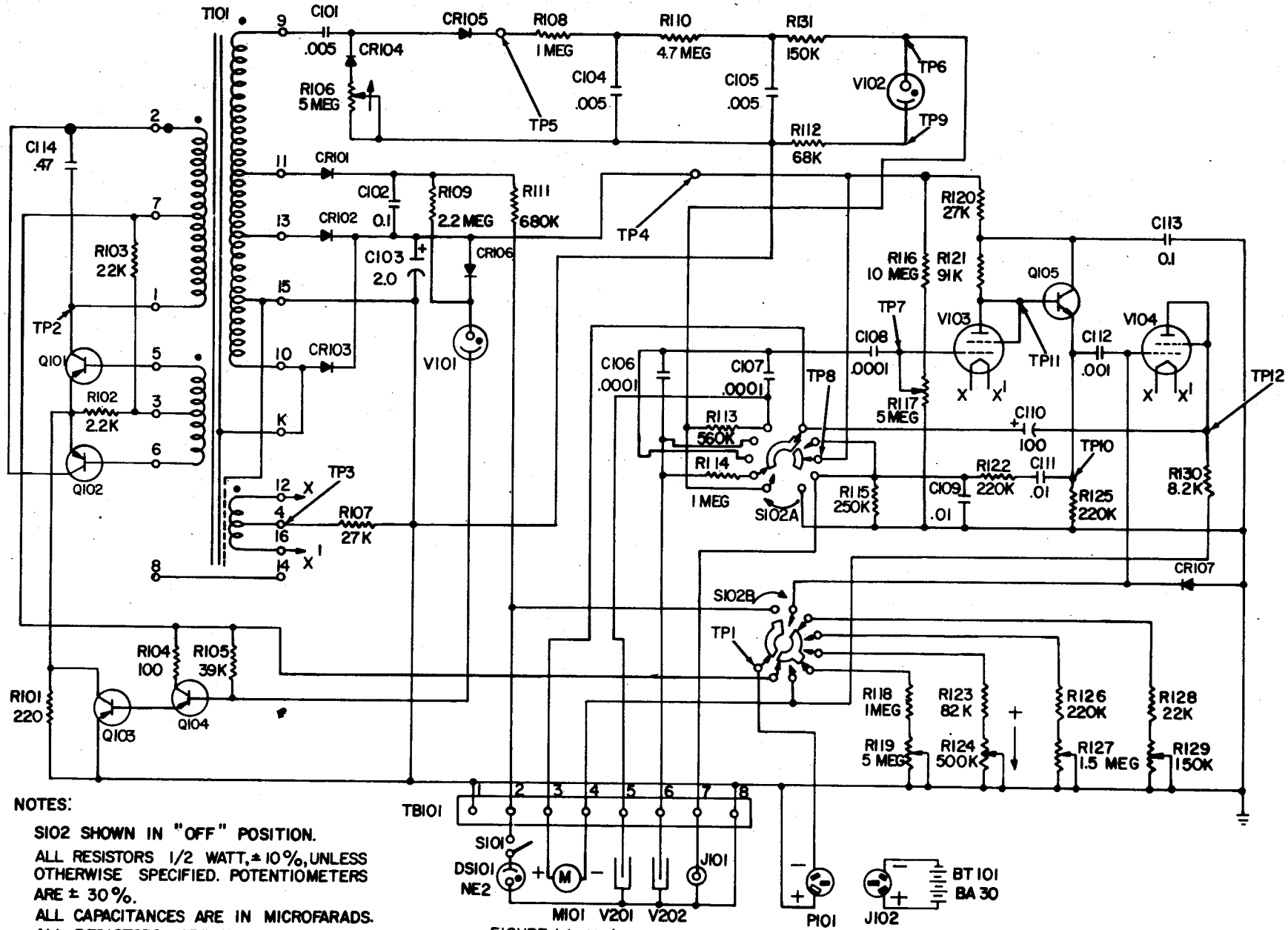

NOTES:

SIO2 SHOWN IN "OFF" POSITION.
 ALL RESISTORS 1/2 WATT, ±10%, UNLESS OTHERWISE SPECIFIED. POTENTIOMETERS ARE ± 30%.
 ALL CAPACITANCES ARE IN MICROFARADS.
 ALL RESISTORS ARE IN OHMS.

FIGURE I-1. AN/PDR-27() SCHEMATIC

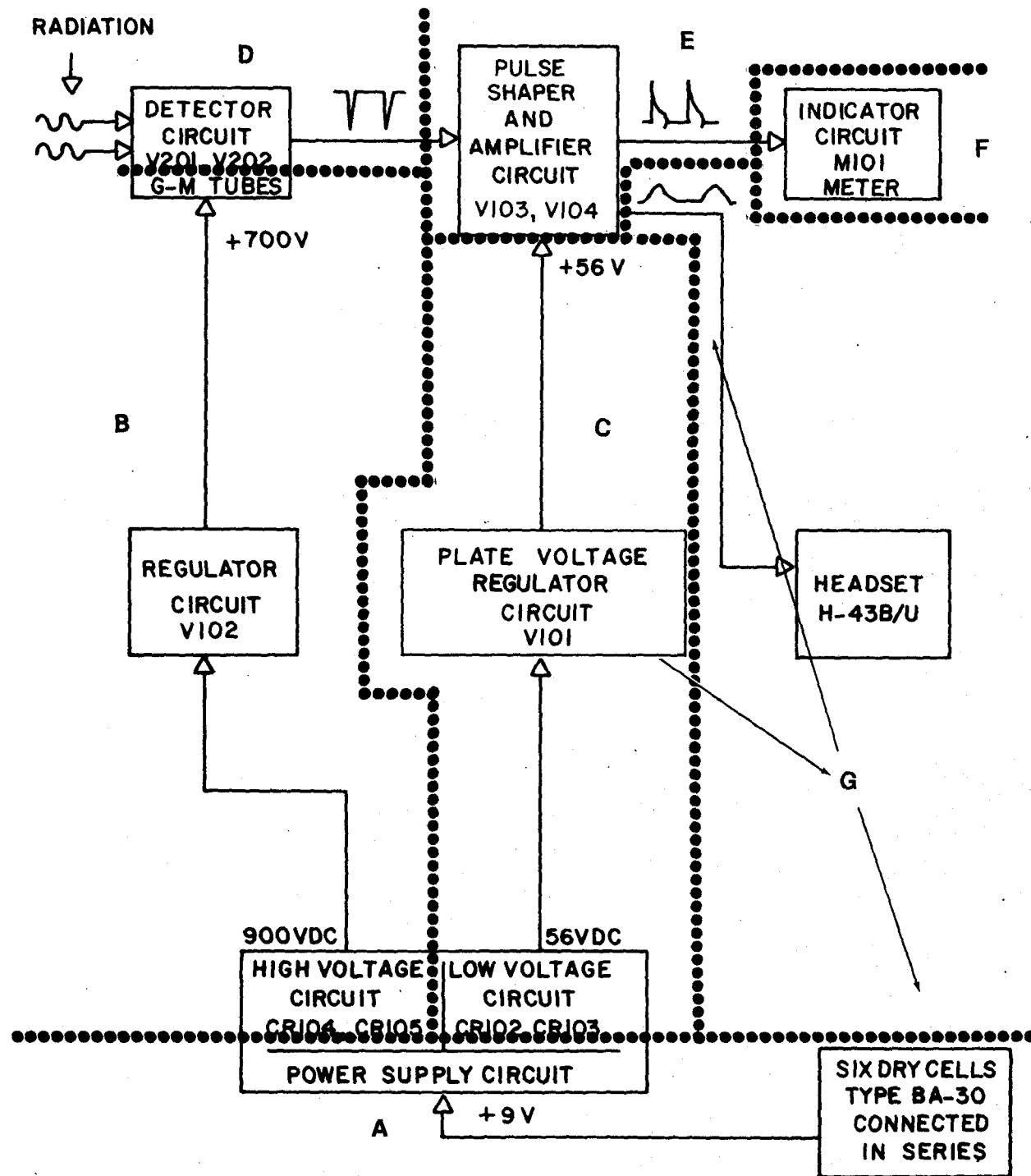

Figure 1-2. BLOCK DIAGRAM

C The power supply also furnishes regulated DC plate voltage to the amplifier and pulse-shaping tubes **V103** and **V104** and also supplies these tubes with 1.2V AC filament voltage.

D The G-M tubes generate voltage pulses when exposed to radioactivity. The average repetition rate of these pulses is proportional to the average radiation field intensity in the vicinity of these tubes. This rate is used in the radiac set to measure the radiation intensity.

E The pulses generated in the G-M tubes are of random amplitude and random duration and are fed to the pulse-shaper circuit and amplifier. This circuit is a one-shot multivibrator which is substantially independent of incoming pulse amplitude, converts the original pulses into pulses of equal width and feeds them to the indicator circuit. The width of these pulses is controlled for each sensitivity range by the appropriate calibration potentiometer.

F The indicator circuit converts the pulses fed from the pulse-shaper and amplifier circuit into a meter reading that is proportional to the pulse repetition rate. The proportionality factor depends on the sensitivity range selected by means of the range switch. The meter scale is changed automatically when the sensitivity range of the radiac set is changed by resetting the range switch. Thus the meter is always direct-reading.

G The voltage-regulator circuit keeps the plate voltage of the amplifier and pulse-shaper circuit constant as the battery voltage decreases with age.

1-10. RADIAC SET CIRCUIT ANALYSIS

a. **Detector Circuit.** The detector circuit consists of G-M tubes **V201** and **V202** anode load resistors **R113** and **R114**, coupling capacitors **C106** and **C107**, range switch **S102** and connectors.

- (1) The two G-M tubes are used as radiation detectors. In the low sensitivity (high-intensity) ranges, detector V202 is disconnected from the high voltage.
- (2) When switch S102 is in the 500 or 50 (mR/hr) position, regulated +700 volt DC is applied through resistor R113 to V201 alone. When S102 is in the 5 or 0.5 (mR/hr) position, V202 is also energized through R114. When the G-M tubes conduct under the influence of an ionizing event, a negative voltage pulse is developed across resistor R113 or R114. This pulse is capacitively coupled to the circuit through C106 or C107.

The output of the G-M, tubes consist of a series of negative-going pulses, one for each ionizing event that occurs within the tube. G-M tubes pulses having an average duration of 80 microseconds and an average amplitude of 100 volts are occasionally encountered. Pulses of reduced amplitude and increased width occur at the input to the circuit because of capacitive loading by the cable connecting the G-M tubes to the circuit. Because of the low values of C106 and C107, input pulses are differentiated into very short duration pulses. The overshoot associated with a differentiated pulse does not occur since the discharge time constant for the coupling circuit is much shorter than the charging time constant in the G-M tube circuit. These negative pulses are then coupled by V103 through C108

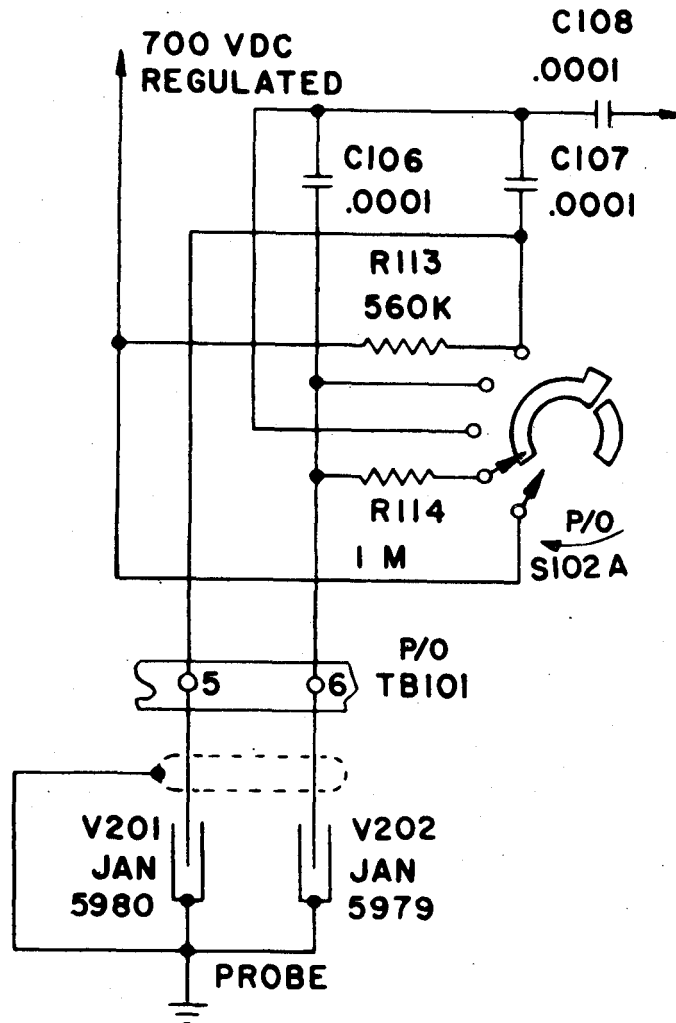

b. **Indicator Circuit.** The indicator circuit consists of capacitor **C110**, resistor **R130** and micrometer **M101**. Meter M101 and resistor R130, in series, are connected in parallel with the capacitor. The complete circuit is connected between the plate of **V104** in the pulse-shaper and amplifier circuit and the V104 plate supply. When V104 conducts, the current pulse charges C110 and causes a meter deflection. During the interpulse interval, V104 is cut-off, and C110 discharges through R130 and M101. This condition keeps the meter deflection nearly constant.

- (1) The function of the indicator circuit is to convert the output pulses from V104 into a relatively steady meter deflection. This deflection is proportional to the radiation intensity. The pulsed output of V104 is smoothed and averaged by C110 and R130 to form a steady meter current. The average current through the meter depends upon the following factors:

- The number of pulses per second received from V104.
- The amplitude and duration of each pulse.

- (2) Since the number of pulses per second is proportional to the radiation intensity, the average meter current will be proportional to the radiation intensity as long as the amplitude and duration of each pulse remains the same.

- (3) When the range is changed through switch S102, the duration of the pulses changes. Therefore, the meter current pulse per second also changes. This current is proportional to the number of pulses per second. The number of pulses per second is, in turn, proportional to the radiation intensity for a given type of radiation. The meter scale can thus be calibrated to indicate milliroentgens per hour (mR/hr) directly.

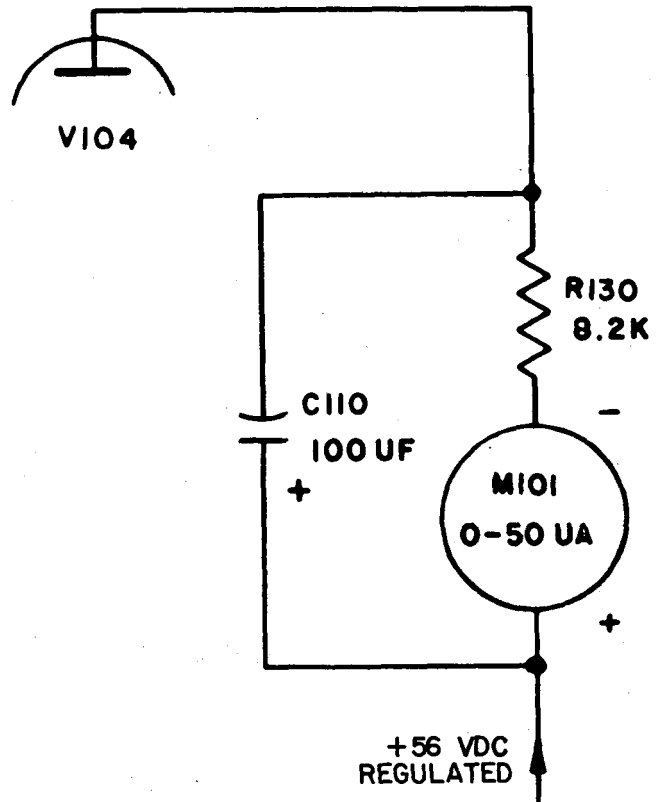

c. **Pulse Shaper and Amplifier Circuit.** The pulse shaper and amplifier circuit consists of variable resistor **R117**, tubes **V103** and **V104**, transistor **Q105**, switch section **S102B** and associated resistors and capacitors. This circuit converts the random-amplitude, random-duration pulses from the detector circuit into pulses of constant amplitude and duration and feeds them to the indicator circuit. Regulation of the plate supply voltage of tubes V103 and V104 is necessary to keep the amplitude and duration of the output pulses to the indicator circuit constant.

- (1) Resistor R117 is a potentiometer which adjusts the voltage on the grid of V103 to the optimum bias point. This adjustment is outlined in paragraph 3-4b, but will be briefly outlined here.
- (2) The grid voltage of V103 is measured by means of a vacuum-tube voltmeter, and resistor R117 is adjusted until the circuit is just out of the free-running condition. The voltage at this point is noted, and R117 is adjusted until the voltage is 0.5 volt higher, which is the optimum bias point. Hum is picked up at the input circuit and amplified. Hum neutralization is provided by application of a voltage of opposite phase to the transformer core, which due to the special construction of the transformer, is capacitively coupled only to the cathode circuit through the filament winding. The major portion of any ripple voltage is thus effectively canceled out, assuring stability of the circuit and also very low background noises in the headphones.
- (3) Tubes V103 and V104, connected as triodes, make up a one-shot multivibrator. Transistor Q105 is connected as an emitter follower and is mainly an impedance matching device to insure proper pulse shape and height even with a relatively low resistance in the grid circuit of V104 (as on the 50 mR range). It also allows headphone output from the emitter, which makes possible a large-shunt-capacitance free cathode circuit, to eliminate sensitivity losses and deterioration in a waveform. In addition, **CR107** clamps the grid of V104 to ground preparing the multivibrator circuit for another pulse immediately following the completion of a preceding pulse.
- (4) In the multivibrator dormant state, no pulses from the detector circuit are received. In this condition, V103 is conducting and V104 is cutoff. Resistor **R121** and transistor Q105 are the plate load for V103. Resistors R116 and R117 form a voltage divider which establishes the steady-state grid bias on V103. The bias and the plate voltage of V103 are such that V103 is conducting. The control grid of V104 is connected through one of the resistance paths of switch section S102B to ground. Tube V104 is cut-off because its cathode is held positive by being connected to the cathode of the conducting tube V103.

- (5) The negative-going pulses from the detector circuit are now applied through coupling capacitor **C108** to the control grid of tube **V103**. These pulses drive the grid of **V103** more negative, which cuts off current flow and causes the plate to become more positive. The rising plate potential of **V103** is coupled to the control grid of **V104** by **Q105** and **C112**, which causes **V104** to conduct heavily. Plate voltage for **V104** is applied through the component parts of the indicator circuit. As long as **V104** conducts, **V103** is cut-off by the rise in the cathode potential of **V104**. This rise is caused by the flow of plate current through common-cathode resistor **R107**. Capacitor **C112** now discharges through the selected resistance (range) path through switch section **S102B** to ground. Tube **V104** conducts until discharge of **C112** is completed while **CR107** eliminates any negative overshoot. At this point the control grid of **V104** will revert to its steady-state bias value and the tube will stop conducting.

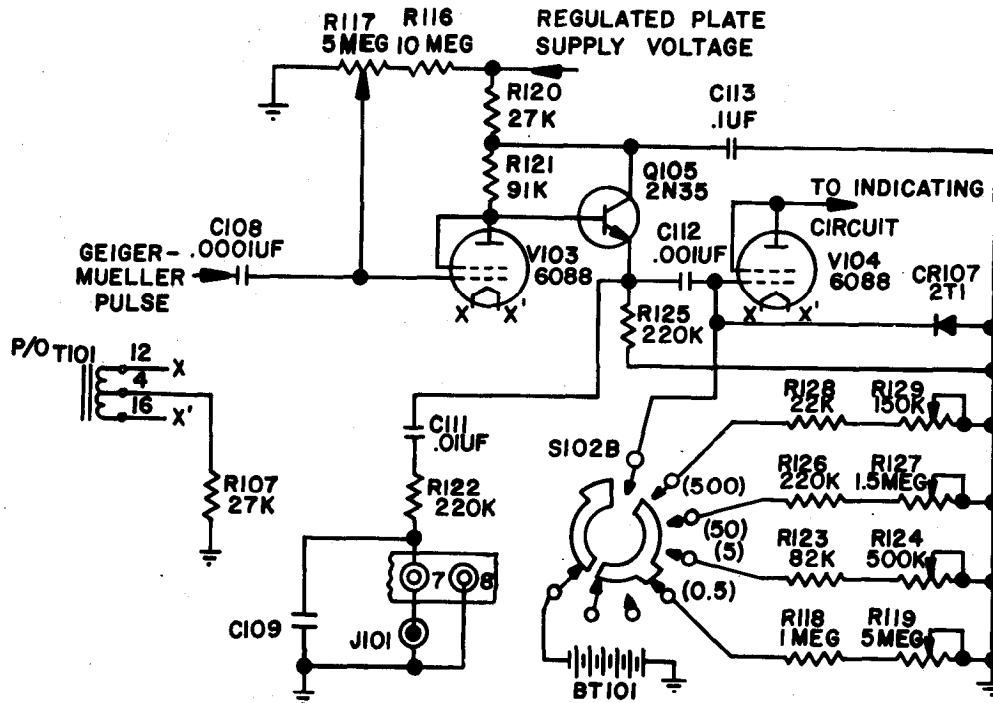

- (6) The length of time that V104 conducts is determined by the R-C time constant of C112 and the selected resistance path to ground. Four separate paths to ground are provided, one for each range. These paths consist of resistor **R128** and calibrating potentiometer **R129** for the 500 mR range resistor **R126** and calibrating potentiometer **R127** for the 50 mR range resistor **R123** and calibrating potentiometer **R124** for the 5 mR range and resistor **R118** and calibrating potentiometer **R119** for the 0.5 mR range.
- (7) When V104 reverts to cutoff, the drop in its cathode potential, directly coupled to the cathode of V103, permits V103 to again conduct its steady-state current. Since the average time between successive pulses from the detector circuit is considerably longer than the time that V104 conducts, the entire circuit reverts to its steady-state condition after each pulse.
- (8) The output of V104 is a series of current pulses and is fed to the indicator circuit. The duration of the V104 output pulses is determined primarily by the selected V104 grid-to-ground time constant circuit, and is thus fixed for any one particular range. Switch section S102B inserts a different resistance for each range in the grid-to-ground time-constant circuit, so that the duration of the output pulse changes when ranges are changed,
- (9) The pulse fluctuations of emitter potential of transistor Q105 occur across resistor **R125** and are applied to an attenuating network consisting of resistor **R122** and capacitors **C109** and **C111**. The AC component of the fluctuations is attenuated by C111, R122, and C109. This voltage is then applied to jack J101 on the front panel. Headset H-43B/U can be connected to this jack for aural monitoring of the radiation intensity.
- (10) The filaments of tubes V103 and V104 are provided with 1.2 volts AC from a secondary winding on transformer **T101**. This voltage is supplied in all positions of S102 except OFF. A center tap on the winding is connected to ground through common-cathode resistor R107.

d. **High Voltage Power Supply Circuits.** The high-voltage power supply circuits consist of a transistorized, saturable-core, square wave "oscillator"; a half-wave doubler rectifier; a "filter circuit" and a regulator circuit. (Fig. 1-3)

(1) Transistor Red Saturable-Core Oscillator.

(a) Nine volts DC is supplied by **BT101** (which consists of six type BA-30, 1.5 volt dry cells in series) to the transistor regulator circuit consisting of **Q103** and **Q104**, the action of which will be described in paragraph (2) below. The regulator output supplies the transistor oscillator. When range switch S102 is turned to the ON position, this voltage is applied through **T101** and **Q101** and **Q102**. Because of the small differences between Q101 and Q102 the forward bias supplied by **R103** favors one transistor. For example, assume it to be transistor Q101. This transistor thus passes more current than Q102 causing the dot end of winding "A" to become more negative with respect to its center-tap.

(b) Because of transformer action, the dot end of winding "B" also becomes more negative than its center-tap, increasing the forward bias of Q101 and bringing it further into conduction. Action is cumulative and Q101 is thus rapidly switched into full conduction. When this occurs the full voltage is applied across winding "A" causing a magnetizing current to flow which is a function of the inductance of this winding and time. An induced voltage is presented in the other windings of the transformer. When the current flowing in winding "A" cannot produce more flux due to saturation of the transformer core, the voltage induced in winding "B" (and in the secondary winding) begins to fall off. This reduction of base drive to Q101 lowers its conduction and thus reduces the current through winding "A". Decreasing current causes a collapsing magnetic field which induces a voltage of opposite polarity in winding "B" (and in all other windings). The dot end of winding "B" thus becomes more positive lowering the conduction of Q101, while the terminal 6 end becomes more negative and brings Q102 into conduction. This is again a cumulative action, and, as before, switching occurs rapidly. Circuit actions are repetitive, and the core saturation time is the total time taken to go from positive core saturation through zero into negative core saturation, or vice versa. The resultant waveshape is very nearly a square, the degree of vertical rise and fall times being limited by the transistor characteristics and transformer loading.

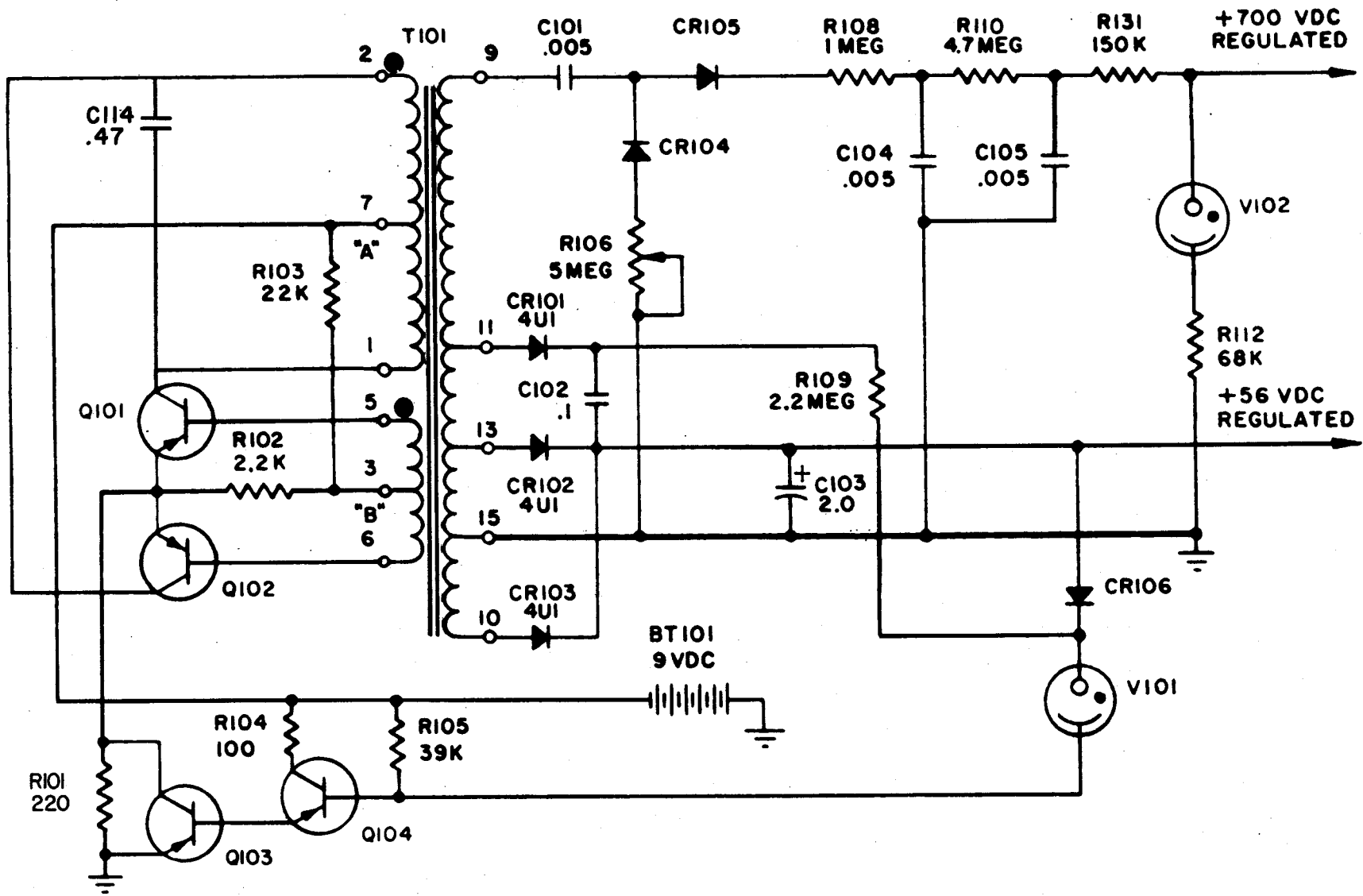

NOTES:
 ALL RESISTANCE ARE IN OHMS.
 ALL CAPACITANCES ARE
 IN MICROFARADS

Figure 1-3 High-Voltage Power Supply Circuit

(2) **Power Supply Voltage-Regulating Circuit.**

Transistors Q103, Q104 and their associated resistors, together with germanium diode **CR106**, resistor **R109** and glow tube **V101**, form a voltage-regulating circuit to keep power supply output constant regardless of variations in battery supply voltage and load, initially, S102 is turned to an ON position, V101 remains extinguished and a negative potential is applied to the base resistor **R104** and to the base of Q103 through the emitter of Q104. This results in Q103 being biased into full conduction and the total battery voltage is applied to the primary circuit of T101. The secondary voltage will now rise until V101 is ignited causing the base potential of Q104 and the Q103 to become more positive, bringing Q103 into a region of lower conduction and causing a voltage drop to appear across Q103. This lowers the input voltage to the primary circuit and thus the secondary voltage causing the current through V101 to decrease. This, in turn, causes the base potential of Q104 and Q103 to become less positive, increasing the conduction through Q103 and lowering the voltage drop across it which again increases the input voltage to the primary circuit of T101. The circuit will then stabilize so that a constant voltage of approximately 6 volts is applied to the primary circuit, the difference between this voltage and the battery voltage appearing as a drop across Q103. This action keeps the input voltage constant with battery voltage changes. Changes in load current are reflected as changes in the average current through V101 which, in turn, cause a restoring voltage change at the input to the oscillator.

(3) Rectifying and Filtering Circuit.

HIGH VOLTAGE (900 VOLTS) present in this equipment when operating. Severe injury or shock can result unless precautions are taken. See warning pages before servicing.

High voltage for G-M tubes V201 and V202 is furnished from secondary taps 9 and 15 of transformer T101, Tap 15 is grounded. This AC voltage is rectified by selenium rectifiers **CR104** and **CR105**, which are connected in a half-wave voltage-doubler circuit. The doubled voltage is built up across capacitor **C101**

The DC voltage pulsations are smoothed and filtered by a filter network consisting of resistors **R108** and **R110** and capacitors C104 and C105, Approximately 900 volts DC is present at the input to the filtering circuit.

(4) Regulating Circuit.

The regulating circuit consists of corona voltage-regulator tube V102 and current limiting resistor **R112**. Tube **V102** regulates the voltage at +700 volts DC for application to G-M tubes V201 and V202.

e. **Regulated Plate Voltage Power Supply.** A secondary winding on transformer T101 provides voltage for the plates of tubes V103 and V104. This voltage is supplied from taps 10 and 13 of the transformer. Selenium rectifiers **CR102** and **CR103** provide full-wave rectification of the square-wave output of the transformer secondary winding. Capacitor **C103** filters the ripple in the rectified voltage. The rectified output is directly connected to the power supply voltage-regulating circuit, the operation of which has been described in paragraph 1-10d (2). The plate voltage of tubes V103 and V104 is thus held at a constant level.

- (1) The load upon the plate voltage power supply consists of a series of short-duration, high-current pulses separated by relatively long periods of zero current. The plate supply voltage must remain constant, not only during pulses but also during interpulse intervals.
- (2) Capacitor C103 helps to keep this voltage constant. During each current pulse, C103 acts as a low-impedance source of power. During the interpulse interval, the charge on C103 is replenished. Capacitor C103 is large enough to prevent a substantial decrease in plate voltage during the load-current pulse.

f. **Meter Illumination Circuit.** The meter illumination circuit consists of pushbutton switch **S101**, glow discharge lamp **DS101** and resistor **R111**. Illumination voltage for the lamp is taken from tap 11 on the secondary winding of transformer **T101**, rectified by **CR101** and filtered by **C102**. The other side of the circuit is grounded. Rectifying the AC voltage eliminates any possibility of hum coupling from the illumination circuit wiring in- to other wiring in the cable harness. When switch **S101** is depressed, lamp **DS101** ig- nites. Resistor **R111** limits the lamp current to its operating value.

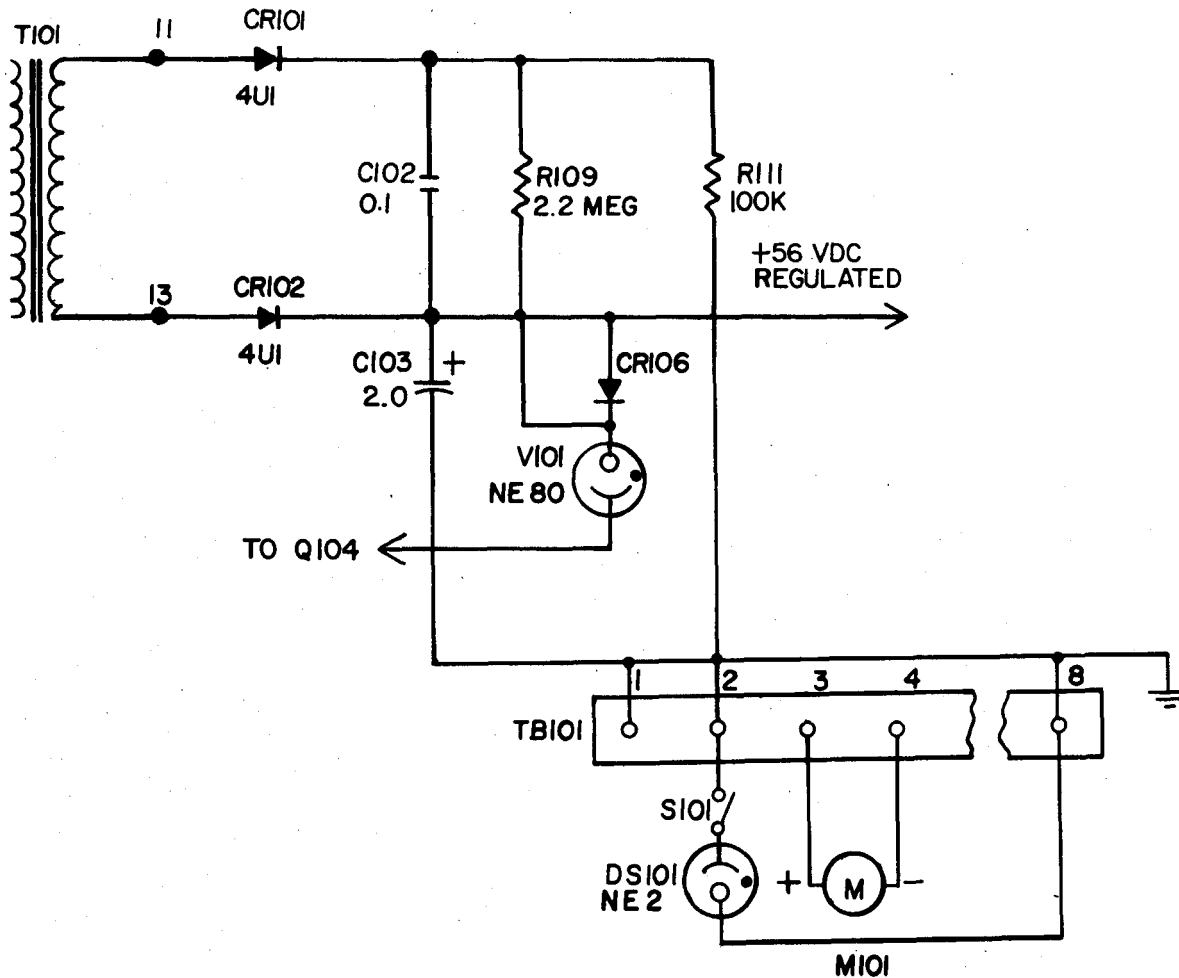

CHAPTER 2 TROUBLESHOOTING

2-1. GENERAL INSTRUCTIONS

a. Troubleshooting at the general support maintenance category includes all the techniques outlined for organizational maintenance and any special or additional techniques required to isolate a defective part. The maintenance procedures are not complete in themselves, but supplement the procedures outlined in TM 11-6665-209-10 and TM 11-6665-209-20.

b. Troubleshooting may be performed while the radiac set is operating or if necessary, after the equipment (or parts of it) has been removed from service. When trouble occurs, certain observations and measurements can be made that will help to determine the source of trouble. Paragraph 2-2 describes the systematic procedure to be followed which will enable the maintenance personnel to isolate the cause of the trouble and correct the fault.

2-2. ORGANIZATION OF TROUBLESHOOTING PROCEDURES

a. **General.** Three steps are used in troubleshooting equipment: Sectionalization, localization, and isolation. Sectionalization means tracing the fault to the major unit. Localization means tracing the fault to the defective section or stage within an assembly or subassembly. Isolation means tracing the fault to the defective part. Some faults can often be isolated by sight, touch, or hearing. The majority of faults, however, must be isolated by detailed electrical, mechanical, or electronic checks.

b. **Sectionalization Checks.** After the trouble has been sectionalized, perform an operational check of the radiac set. The operational check serves as a check of the localization technique. In addition, assemblies or subassemblies, in some cases, parts can be localized by the methods listed below.

- (1) **Visual Inspection.** The purpose of visual inspection is to locate faults without testing or measuring circuits or components. All visual signs should be analyzed to help locate the fault to a particular subchassis, stage, or part. Mechanical faults are most often localized through visual inspection.
- (2) **Pluck-Out Parts.** Defective pluck-out parts will be the cause of many troubles. Remove and test all pluck-out parts suspected of being faulty. Replace each defective part with an identical part known to be good.
- (3) **Troubleshooting Table.** The malfunctions listed in the troubleshooting table (para. 2-5) will aid in localizing trouble to a component part, subassembly, or assembly.

c. **Voltage and Resistance Measurements.** This equipment is transistorized. Observe all cautions given to prevent transistor damage. Make voltage and resistance measurements in this equipment only as specified in figure 2-1.

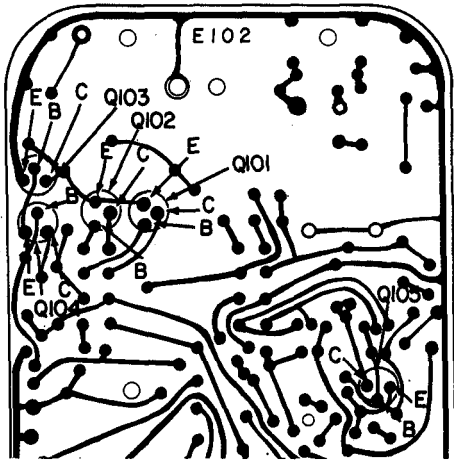

TRANSISTOR		VOLTAGES DC TO GROUND (VOLTS)			RESISTANCES (OHMS) GROUND SIDE +		
		E	B	C	E	B	C
Q101	E B C	-2.5	+0.1	-8.1	200	1000	12000
Q102	E B C	-2.5	+0.1	-8.1	200	1000	12000
Q103	E B C	0.0	-.4	-2.5	0	∞	200
Q104	E B C	-0.4	-0.6	-7.8	∞	60000	12000
Q105	E B C	+28.7	+28.4	+44.46	100 K	150 K	*10 MEG

V102 JAN 5962

+700 VOLTS REGULATED
(ELECTROSTATIC VOLT METER)

R = ∞

NOTE:
VTVM READINGS ARE INACCURATE

CAP V +1.4 VOLTS (VTVM)
R = 68 K

JAN 6088

	VOLTAGES (VOLTS) DC TO GROUND					RESISTANCES (OHMS)				
	P	SG	F+	G	F-	P	SG	F+	G	F-
V103	28.2	28.2	5.4	3.5	5.4	*10 MEG	*10 MEG	27K	0 TO 5MEG	27K
V104	5.4	5.4	5.4	0.0	5.4	*10 MEG	*10 MEG	27K	*150K TO 1.5 MEG	27K

VOLTAGES DC TO GROUND (VOLTS)

105 VDC (ELECTRO-STATIC VM)

0.0 (VTVM) 54V 54V +700+700 0.0 0.0

	1	2	3	4	5	6	7	8	TB101
RESISTANCES TO GROUND (OHMS)	0.0	*10 MEG	*10 MEG	*10 MEG	*∞	*∞	∞	0.0	

RANGE SWITCH ON 5 MR/HR RANGE. NO RADIATION.
RESISTANCE CHECK - BATTERY DISCONNECTED, ALL TRANSISTORS REMOVED. METER USED - 20K OHMS/VOLT.
VOLTAGE MEASUREMENT - VTVM EXCEPT WHERE OTHERWISE SPECIFIED.
*-DIODE IN CIRCUIT. ORIENT METER LEADS FOR PROPER READING.
Δ-DEPENDENT ON BIAS SETTING OF R117.
VOLTAGE TOLERANCE ±20%.

Figure 2-1. TYPICAL VOLTAGE AND RESISTANCE AND THEIR LOCATIONS.

2-3. REPAIR PARTS, TEST EQUIPMENT AND TOOLS

Test equipment and tools required: Table 2-1 below lists the tools and test equipment required for troubleshooting and repair of the radiac set at general support maintenance.

Table 2-1. TEST EQUIPMENT AND TOOLS

NOMENCLATURE	NSN
Multimeter TS-352B/U	6625-00-553-0142
Voltmeter, Electronic ME-30A/U	6625-00-643-1670
Oscilloscope OS-8/U (or equivalent)	6625-00-643-1740
Test Set, Electronic Tube TV-2/U	6625-00-699-0263
Test Set, Transistor TS-1836D/U	6625-00-138-7320
Calibrator Set, Radiac AN/UDM-2	6625-00-179-9037
Tool Kit, Electronic Equipment TK-105/U	5180-00-610-8177

2-4. WAVEFORMS AND TEST POINTS

- a. Waveforms shown in figure 2-2 are normal waveforms, unless otherwise noted.
- b. Test points shown in figure 2-2 are located on the printed circuit board. Ensure that good contact has been made when making waveforms and voltage measurements.

WAVEFORM	TEST POINT	APPROX AMPLITUDE VOLTS PEAK TO PEAK	RADIO-ACTIVE TEST SAMPLE USED	REMARKS
	2	10	NO	
	3	0.05	NO	
	3	12	YES	
	4	0.2	NO	
	7	0.1	NO	
	10	0.6	NO	NORMAL RIPPLE
	10	1.5	NO	ABNORMAL RIPPLE
	10	18	YES	
	11	15	YES	
	12	0.2	YES	NORMAL INDICATION RADIATION AND NO RADIATION

RANGE SWITCH SET AT 5.
SWEEP TIME-2000 MICROSECONDS.

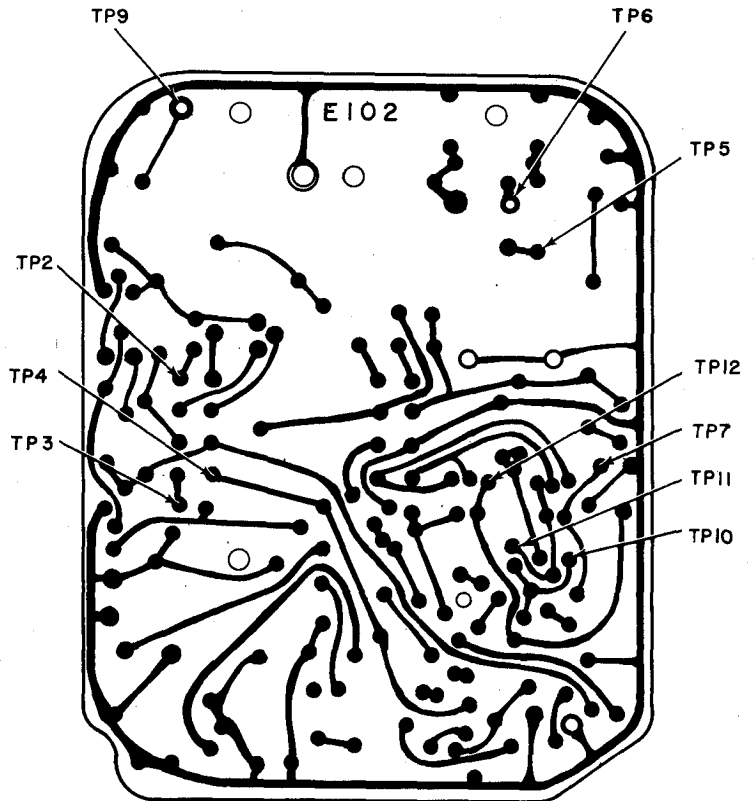

Figure 2-2. WAVEFORM DIAGRAM AND TEST POINT LOCATIONS.

CAUTION

This equipment is transistorized. Before connecting test equipment, insulate test prods and clips with insulating tape. Leave an absolute minimum of exposed metal, and be extremely careful to avoid short circuits, they may cause extensive damage. DO NOT make resistance measurements unless specifically directed to do so.

2-5. TROUBLESHOOTING PROCEDURES

The malfunctions listed in table 2-2 are presumed to exist after all lower level troubleshooting procedures and corrective actions have been performed. Perform corrective actions in the order given. Do not proceed to the next action when the measures already taken have eliminated the trouble. Use resistor and capacitor color codes (Fig. FO-1) to find the value of components.

Table 2-2. TROUBLESHOOTING PROCEDURES



HIGH VOLTAGE (900 VOLTS) is present in this equipment.

SYMPTOM

PROBABLE TROUBLE

CORRECTIVE PROCEDURE

1. Range Scale does not change properly.
 - Loose set screw-in mechanical train.
 - Tighten set screw (para. 3-2).
2. No battery indication on meter.
 - Step 1. Defective meter.
 - Press meter light switch. If light comes on, check meter.
 - If light does not come on go to Step 2 below.
 - Step 2. Battery connections defective.
 - Check all battery connections; trace voltage path with multimeter from battery compartment to range switch.

Table 2-2. TROUBLESHOOTING PROCEDURES - continued



HIGH VOLTAGE (900 VOLTS) is present in this equipment.

SYMPTOM**PROBABLE TROUBLE****CORRECTIVE PROCEDURE**

3. No or low readings on meter when test sample is used.

Step 1. Defective tube V202 in probe.

Remove case to reach TB101. Check for voltage at pins 5 and 6 when range switch is in 5.0 or 0.5 position. If voltage is available at test points, check tubes V201 and V202. If voltage is not available, high voltage power supply is defective.

Step 2. Defective high voltage power supply.

Remove case to reach TP6. Check for voltage at TP6 when range switch is in any on position. If voltage is not available, high voltage power supply is defective.

4. No readings on meter or audio heard in headset when test sample is used to check all ranges.

Defective pulse shaper circuit (V103, V104, or Q105).

Remove case to reach PCB. Check for proper waveform at TP11. If proper waveform exists change Q105. If proper waveform does not exist change V103.

5. No audio heard in headset but meter indicates normal.

Step 1. Defective headset.

Check headset leads with an ohmmeter while listening in phases. If no continuity is measured and no battery click is heard, headset is defective.

Step 2. Audio circuit in radiacmeter defective.

Check wiring and components C111, R122, C109, and J101.

Step 3. Voltage and resistance measurements.

This equipment is transistorized. Observe all cautions given to prevent transistor damage. Make voltage and resistance measurements in this equipment only as specified in figure 2-1. Use resistor and capacitor color codes (Fig. FO-1) to find the value of components.

CHAPTER 3

GENERAL SUPPORT REPAIR PROCEDURES AND ADJUSTMENTS

3-1. GENERAL PARTS REPLACEMENT TECHNIQUES

All of the parts and assemblies in the radiac set can easily be reached without any special procedures. After any repairs check calibration by use of AN/UDM-2.



Remove the batteries from the equipment before making any repairs.

NOTE

Before any part is removed, note the position of the part and its lead. Wire replacement parts in essentially the same position to avoid undesired coupling and shorting together of wires. If necessary, use tags.

3-2. DISASSEMBLY/ASSEMBLY PROCEDURES OF RADIAC SET AN/PDR-27J.
(Figures 3-1 through 3-3)

NOTE

General support maintenance includes all repair operations covered in lower level manuals as well as those covered in this chapter.

- a. **Removal of Front Panel Assembly.** (Figure 3-1). Loosen six screws (2) from front panel assembly (1) and remove front panel assembly from housing.
- b. **Removal of Detector Assembly.** (Figure 3-1).
 - (1) Remove terminal lug (29) from terminal board TB101 (28).
 - (2) Loosen nut (6) and remove detector cable (7) from front panel assembly (1).
- c. **Replacement of Detector Assembly.**
 - (1) Insert detector cable (7) through top of front panel assembly and tighten nut in subparagraph b (2) above.
 - (2) Replace terminal lugs removed in subparagraph b (1) above and tighten screws.
- d. **Removal of Printed Circuit Board Z101 (PCB).** (Figure 3-2)
 - (1) Remove three screws (32), four lockwasher (21), three flat washers (31), four nuts (22), and slowly remove Z101 PCB (25) from front panel assembly (1).
 - (2) Remove four plastic extension shafts (33), pressure plate (34), and pressure spring (35), from front panel assembly (1).
 - (3) Remove terminal lugs from bottom row of terminal board TB101 (28).
 - (4) Remove connector plug (23) (Fig. 3-1), from battery compartment and remove PCB from front panel assembly (1).

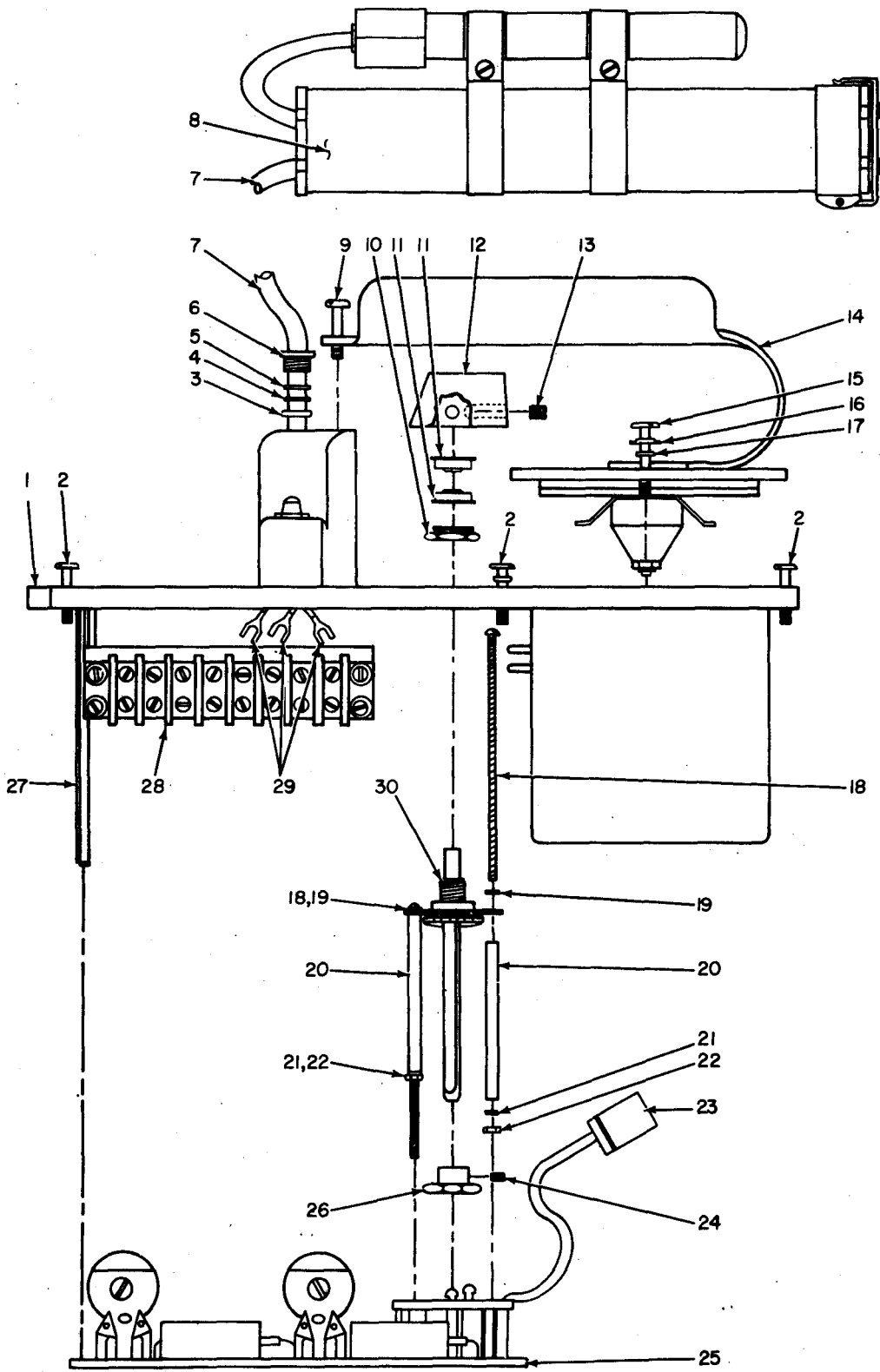

Figure 3-1. AN/PDR-27J - EXPLODED TOP VIEW

Legend for figure 3-1:

- | | |
|--------------------------|---------------------------------|
| 1. Front Panel Assembly. | 16. Lockwasher. |
| 2. Screw (6). | 17. Flat Washer. |
| 3. Rubber Gasket. | 18. Support Screw (2). |
| 4. Flat Washer. | 19. Flat Washer (2). |
| 5. Flat Washer. | 20. Space Tube (2). |
| 6. Nut. | 21. Lockwasher (5). |
| 7. Detector Cable. | 22. Nut (4). |
| 8. Detector Assembly. | 23. Connector Plug. |
| 9. Captive Screw. | 24. Setscrew. |
| 10. Retainer Nut Seal. | 25. Printed Circuit Board Z101. |
| 11. Gasket (2). | 26. Sprocket, Wheel Segment. |
| 12. Knob. | 27. Stud (5). |
| 13. Setscrew. | 28. Terminal Board TB101. |
| 14. Handle. | 29. Terminal Lug (3). |
| 15. Screw, Captive. | 30. Switch S102. |

Figure 3-1. AN/PDR-27J - EXPLODED TOP VIEW.

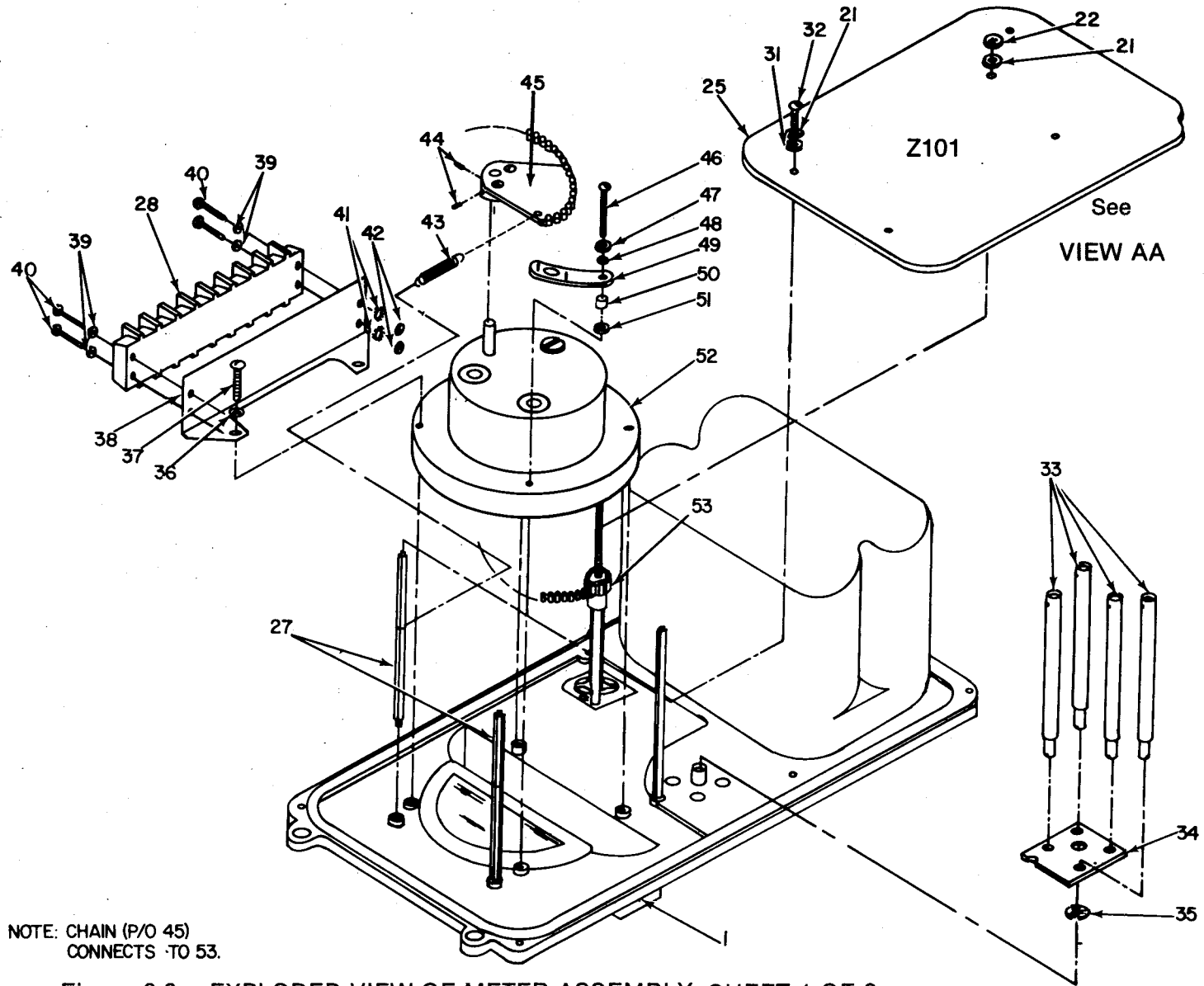

Figure 3-2. EXPLODED VIEW OF METER ASSEMBLY. SHEET 1 OF 2.

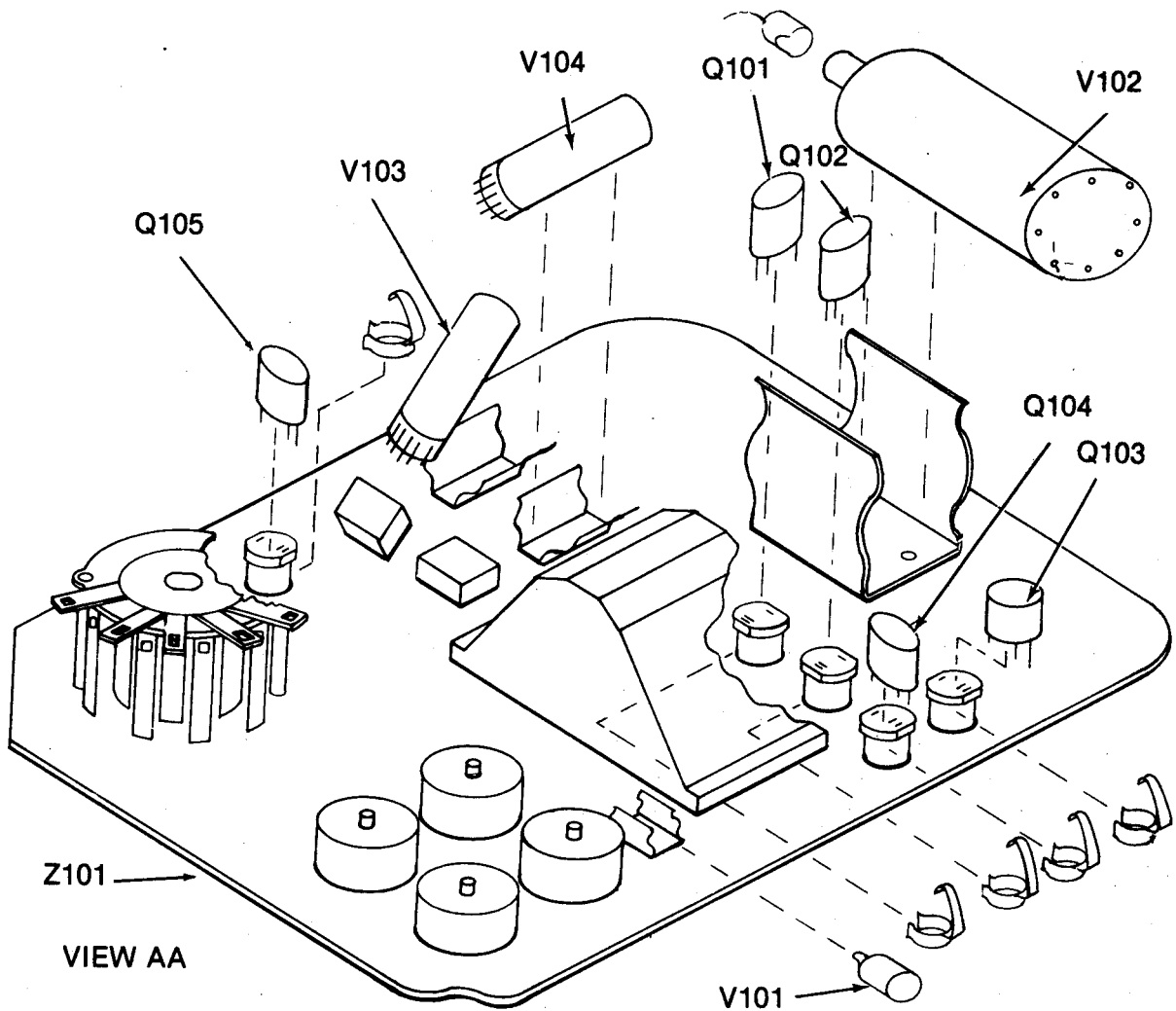

Figure 3-2. EXPLODED VIEW (Z101) PCB. SHEET 2 OF 2.

Legend for Figure 3-2

- | | |
|----------------------------------|------------------------------|
| 31. Flat Washer (3). | 43. Spring. |
| 32. Screw (3). | 44. Setscrew (2). |
| 33. Plastic Extension Shaft (4). | 45. Sprocket, Wheel Segment. |
| 34. Pressure Plate. | 46. Screw. |
| 35. Pressure Spring. | 47. Lockwasher. |
| 36. Lockwasher (2). | 48. Flat Washer. |
| 37. Screw (2). | 49. Terminal Board TB2. |
| 38. Bracket, Mounting. | 50. Supporting Post. |
| 39. Flat Washer. | 51. Flat Washer. |
| 40. Screw. | 52. Meter M101. |
| 41. Lockwasher. | 53. Chain, Weldless. |
| 42. Nut. | |

e. **Removal of Pluck-Out Electron Tubes and Transistors on the Printed Circuit Board PCB Z101 (25)**

- (1) Remove Z101 PCB from mounting studs as in subparagraph d above.
- (2) Lifting Z101 PCB up from mounting studs turn PCB over with components facing upwards.

NOTE

When replacing electron tubes V103 and V104 insure red dot on tubes are aligned with markings of Z101 PCB.

NOTE

When replacing/removing transistors observe positions of pins. Be careful not to bend pins when replacing transistors.

- (3) Replace PCB as in subparagraph j below.
- (4) After replacing of either electron tubes V102, V103, V104, or transistor Q105 make the necessary adjustments given in paragraph 3-4.

NOTE

Adjusting resistor R117 may effect the calibration procedure. If difficulty is encountered, set bias voltage at TP3 to +5.5 volts d.c. and reattempt to calibrate.

f. Removal of Meter M101 (52). (Figure 3-2)

- (1) Remove two screws (37), two lockwashers (36), from rear of meter M101 (52) and remove terminal board TB101 (28) from meter.
- (2) Remove spring (43) from stud (27).
- (3) Loosen two set screws (44), and remove sprocket wheel segment (45) from meter.
- (4) Unsolder and tag wires from rear of meter M101 (52).
- (5) Remove screw (46), lock washer (47), flat washer (48), terminal board TB2 (49), supporting post (50) and flat washer (51) from rear of meter and remove meter from front panel assembly (1).

g. Replacement of Meter M101.

- (1) Position meter M101 (52), on front panel assembly (1) and replace hardware removed in subparagraph e (5) above.
- (2) Place lock washer (47), flat washer (48), terminal board TB2 (49), supporting post (50) removed in subparagraph f (5) above.
- (3) Replace wires removed in subparagraph e (4) above.
- (4) Position terminal board TB101 (28), on meter M101 (52) and secure with hardware removed in subparagraph e (1) above.
- (5) Replace sprocket wheel segment (45) on meter M101 shaft.
- (6) Holding sprocket wheel segment (45) in position (chain tight), tighten set screws (44) and reconnect spring (43) to stud (27).
- (7) Align meter window scale with switch setting, and tighten set screws (44).

h. Removal of the Mechanical Portion of Selection Switch S102 in the 0.5 Position. (Figure 3-1)

- (1) Remove one set screw (13) from knob (12). Pull upwards on knob to remove.
- (2) Remove two gaskets (11) from under knob (12).
- (3) Remove retainer nut seal (10). Pull switch out from bottom of front panel assembly (1).
- (4) Remove two extension and support screws (18), two nuts (22), two lock washers (21), two long space tubes (20), two flat washers (19) from mechanical switch (30).
- (5) Remove sprocket wheel (26) from switch shaft by removing one set screw (24).

i. Replacement of the Mechanical Portion of Selection Switch S102.

- (1) Replace and secure extension support screws (18) through mechanical switch S102 (30) with all hardware removed in subparagraph g (4) above.
- (2) Replace mechanical switch (30) with location post into indentation of front panel assembly (1) and secure with retainer nut seal (10) and gaskets (11) removed in subparagraphs h (2) and h (3) above.

j. Replacement of Printed Circuit Board (PCB) Z101. (Figure 3-1)

- (1) Replace the connector plug (23) to battery compartment.
- (2) Position the PCB on the five supporting studs (27).
- (3) Replace and secure all terminal lugs removed in subparagraph d (3) above.
- (4) Replace the pressure spring (35), pressure plate (34) and four plastic extension shafts (33) and secure PCB (25) with hardware removed in subparagraph d (1) above.

k. Replacement of Front Panel Assembly. Replace front panel assembly (1) and secure with hardware removed in subparagraph a above.



Remove the batteries from the equipment before making any repairs.

**3-3. DISASSEMBLY/ASSEMBLY PROCEDURES OF DETECTOR DT-196/PDR-27J.
(Figure 3-3)**

CAUTION

Since the mica window is only 0.0005 inch thick, it is extremely fragile. Do not touch the window under any circumstances, because damage to the tube will result. Do not rely upon the guard ring to protect the mica window. The guard ring openings are large enough so that sharp objects may pierce the window.

a. Removal of Latch Cover. (Figure 3-3)

- (1) Remove screw (71), from slipring (72), and remove latch cover assembly (73 thru 76), and slipring (72), from detector assembly (8).
- (2) Remove two screws (76), two lockwashers (75) and remove latch cover (73) from retaining clip (74).

b. Replacement of Latch Cover.

- (1) Position latch cover (73) on retaining clip (74), and secure with hardware removed in subparagraph a (2) above.
- (2) Replace slipring (72) on detector assembly (8).
- (3) Place latch cover (73) in slipring (72) and secure with hardware removed in subparagraph a (1) above.

c. Removal of Electron Tube V202. (Figure 3-3)

- (1) Remove retainer nut (60) from detector assembly (8), slowly remove wires from inside detector assembly (8) and remove gasket (58).
- (2) Using needle nosed pliers remove electrical cap (57) from electron tube V202 (77).
- (3) Remove retainer nut (69) and guard (70) from detector assembly (8).
- (4) Push electron tube V202 (77) from detector assembly (8) (approximately 1½ inches).
- (5) Hold detector assembly in one hand and remove electron tube V202 from the detector assembly (8).

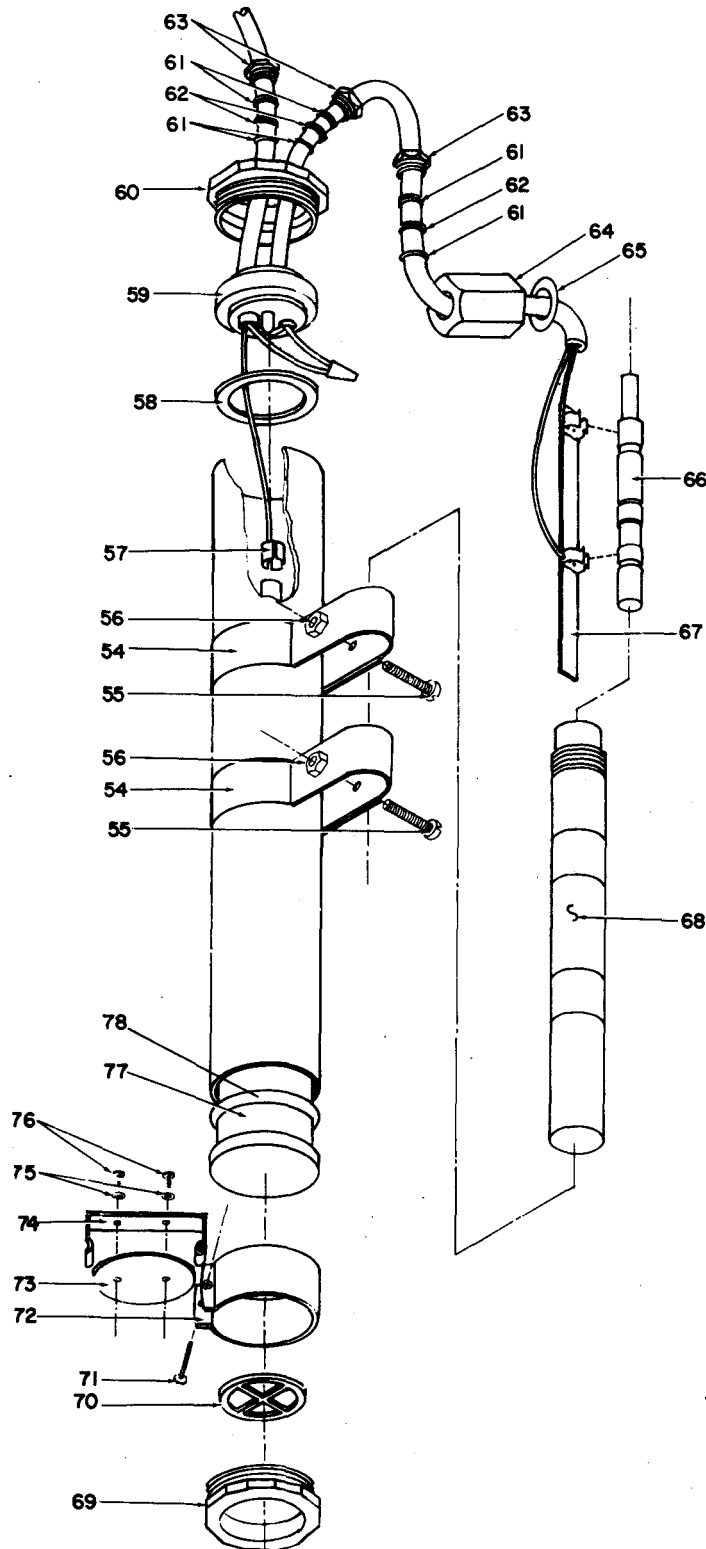

Legend Figure 3-3.

- 54. Clamp.
- 55. Screw, Retaining.
- 56. Nut, Self Locking, Clinch.
- 57. Electrical Cap.
- 58. Gasket.
- 59. Cap.
- 60. Retainer Nut.
- 61. Gasket, Rubber.
- 62. Flat Washer.
- 63. Nut.
- 64. Nut.
- 65. Gasket, Rubber.
- 66. Electron Tube V201.
- 67. Electron Tube Holder.
- 68. Tube Assembly.
- 69. Retainer Nut.
- 70. Guard.
- 71. Screw.
- 72. Slip Ring.
- 73. Latch Cover.
- 74. Retaining Clip.
- 75. Lock Washer (2).
- 76. Screw (2).
- 77. Electron Tube V202.
- 78. Gasket.

Figure 3-3. DETECTOR DT-196/PDR-27J - EXPLODED VIEW.

d. Replacement of Electron Tube V202.

- (1) Place gasket (78) in position on electron tube V202 (77).
- (2) Insert electron tube V202 (77) into detector assembly.
- (3) Place guard (70) and retainer nut (69) over end of electron tube (77) and use retainer nut (69) to push gasket into tube assembly. Tighten retainer nut.
- (4) Replace electrical cap (57) removed in subparagraph c (2) above.
- (5) Position wires removed in subparagraph c (1) above and secure with retainer nut removed in subparagraph c (1) above and be sure not to twist wires.

e. Removal of Electron Tube V201. (Figure 3-3)

- (1) Loosen retainer nut (63) one full turn.
- (2) Remove nut (64), making sure wires do not twist and remove electron tube (66) assembly from small housing.
- (3) Remove plastic shield (not shown) from tube assembly (68) and remove electron tube V201 from electron tube holder (67).

f. Replacement of Tube V201.

- (1) Position electron tube V201 in electron tube holder (67) and replace plastic shield.
- (2) Insert tube assembly into housing (68) and tighten with nut (64) making sure wires do not twist.
- (3) Tighten retainer nut (63).

3-4. ADJUSTMENTS

NOTE

Perform the following steps when electron tube V102 has been replaced.

a. Adjustment of Resistor R106.

- (1) Connect test equipment as shown below.
- (2) Adjust resistor R106 until 1 volt is recorded on the voltmeter.

NOTE

Perform the following steps when any of the following components have been replaced (V103, V104, and Q105).

b. Adjustment of Resistor R117.

- (1) Set the range switch S102 to 50 mR/hr range.
- (2) Rotate resistor R117 clockwise until the radiacmeter indicates full scale.
- (3) Connect test equipment as shown below.
- (4) Slowly rotate resistor R117 counterclockwise until the multimeter indicates the lowest reading.
- (5) Continue rotating resistor R117 counterclockwise until the multimeter indicated 0.5 ± 0.1 vdc higher than the reading in step 4 above.

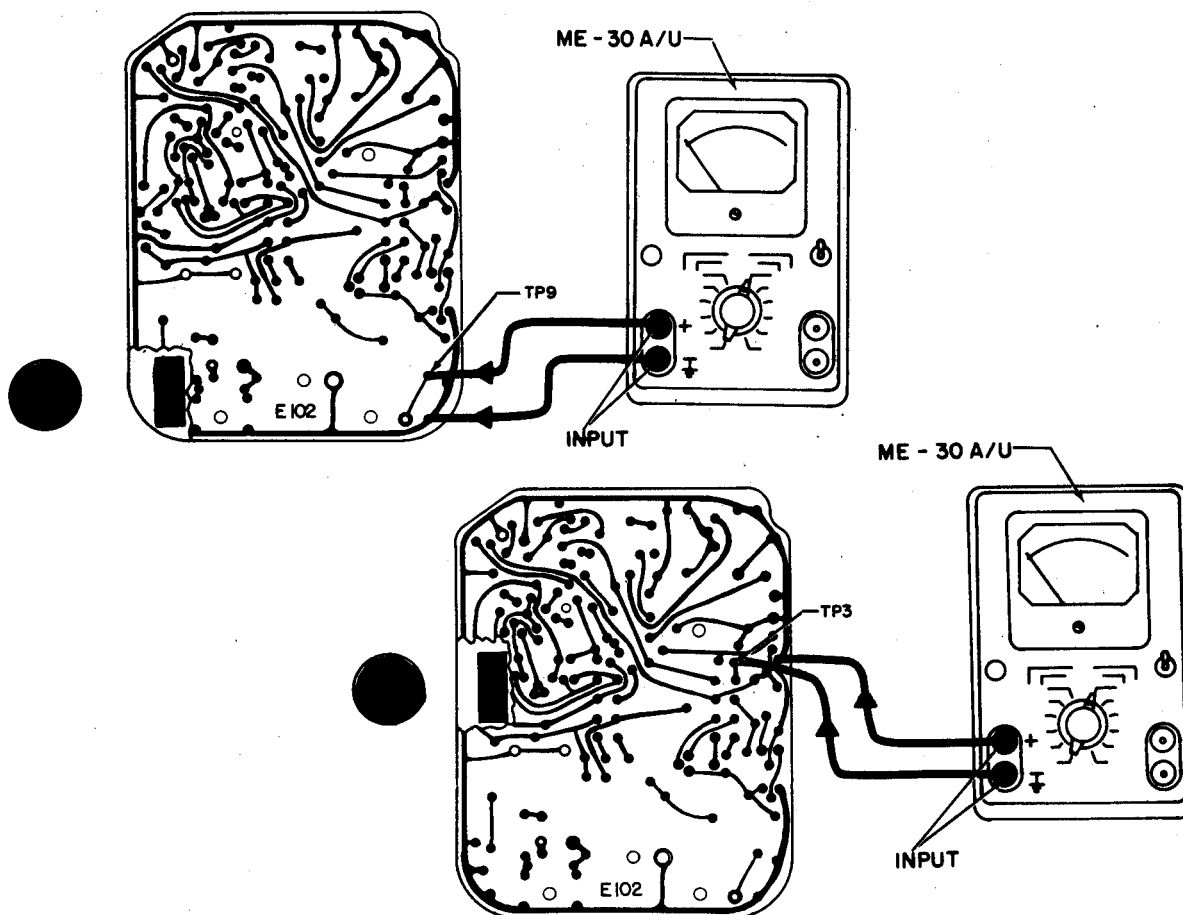

APPENDIX A

REFERENCES

DA PAM 310-4	Index of Technical Manuals, Technical Bulletins, Supply Manuals (Types 7, 8, and 9), Supply Bulletins, Lubrication Orders, and Modification Work Orders.
TB 43-0118	Field Instructions for Painting and Preserving Electronics Command Equipment including Camouflage Pattern Painting of Electrical Equipment Shelters.
TB 43-180	Calibration Requirements for the Maintenance of Army Material.
TB SIG 355-1	Depot Inspection Standard for Repaired Signal Equipment.
TB SIG 355-2	Depot Inspection Standard for Refinishing Repaired Signal Equipment.
TB SIG 355-3	Depot Inspection Standard for Moisture and Fungus Resistant Treatment.
TM 11-1176	Radiac Calibrator Set AN/UDM-1.
TM 11-1214	Instruction Book for Oscilloscope OS-8A/U.
TM 11-5965-247-12P	Operator and Organizational Maintenance Repair Parts and Special Tool Lists and Maintenance Allocation Chart: Headset, Electrical H-43B/U.
TM 11-5965-247-35P	Field and Depot Maintenance Repair Parts and Special Tool Lists: Headset, Electrical H-43B/U.
TM 11-6625-203-12	Operator and Organizational Maintenance: Multimeter AN/URM-105, Including Multimeter ME-77/U and ME-77C/U.
TM 11-6625-239-12	Operator and Organizational Maintenance Manual: Test Sets, Electron Tube TV-2/U, TV-2A/U, TV-2B/U and TV-7D/U. Electronic Multimeter TS-505A/U, TS-505B/U and TS-505C/U.
TM 11-6625-316-12	Operator and Organizational Maintenance Manual: Test Sets, Electron Tube TV-21U, TV-1A/U, TV-1B/U, and TV-2C/U.
TM 11-6625-366-10	Operator's Manual for Multimeter TS 325B/U
TM 11-6625-539-15	Operator, Organizational, Field and Depot Maintenance Manual: Transistor Test Set TS-1836/U.

TM 11-6665-209-40

- TM 11-6665-209-10 Operator's Manual, Radiac Sets AN/PDR-27J, AN/PDR-27L and AN/PDR-27Q.
- TM 11-6665-209-20 Organizational Manuals AN/PDR-27J, AN/PDR-27K, and AN/PDR-27L.
- TM 11-6665-227-12 Operator's and Organizational Maintenance Manual: Calibrator Set, Radiac AN/UDM-2 (NSN 6665-00-179-9037).
- TM 3-6665-264-10 Operator's Manual: Radioactive Test Sample, Krypton 85, GAMMA, MX-7338/PDR-27R.
- TM 38-750 The Army Maintenance Management System (TAMMS).

★ U.S. GOVERNMENT PRINTING OFFICE: 1981-703029/1189

By Order of the Secretary of the Army

E. C. MEYER
General, United States Army
Chief of Staff

Official:

J. C. PENNINGTON
Major General, United States Army
The Adjutant General

DISTRIBUTION:

To be distributed in accordance with DA Form 12-50, Direct and General Support maintenance requirements for AN/PDR-27J.



THEN... JOT DOWN THE DOPE ABOUT IT ON THIS FORM, TEAR IT OUT, FOLD IT AND DROP IT IN THE MAIL!

SOMETHING WRONG WITH THIS MANUAL?

FROM: (YOUR UNIT'S COMPLETE ADDRESS)

Commander
Stateside Army Depot
ATTN: AMSTA-US
Stateside, N.J. 07703

DATE 10 July 1975

PUBLICATION NUMBER

TM 11-5840-340-12

DATE

23 Jan 74

TITLE

Radar Set AN/SPS-76

BE EXACT... PIN-POINT WHERE IT IS

PAGE NO.	PARA-GRAPH	FIGURE NO.	TABLE NO.
2-25	2-28		
3-10	3-3		3-1
5-6	5-8		
		FO3	

IN THIS SPACE TELL WHAT IS WRONG AND WHAT SHOULD BE DONE ABOUT IT:

Recommend that the installation antenna alignment procedure be changed throughout to specify a 2° IFF antenna lag rather than 1°.

REASON: Experience has shown that with only a 1° lag, the antenna servo system is too sensitive to wind gusting in excess of 27 knots, and has a tendency to rapidly accelerate and decelerate as it hunts, causing strain to the drive train. Hunting is minimized by adjusting the lag to 2° without degradation of operation.

Item 5, Function column. Change "2 db" to "3db."

REASON: The adjustment procedure for the TRANS POWER FAULT indicator calls for a 3 db (500 watts) adjustment to light the TRANS POWER FAULT indicator.

Add new step f.1 to read, "Replace cover plate removed in step e.1, above."

REASON: To replace the cover plate.

Zone C 3. On J1-2, change "+24 VDC to "+5 VDC."

REASON: This is the output line of the 5 VDC power supply. + 24 VDC is the input voltage.

TEAR ALONG DOTTED LINE

TYPED NAME, GRADE OR TITLE, AND TELEPHONE NUMBER

SSG I. M. DeSpiritof 00-1776

SIGN HERE:

SSG I. M. DeSpiritof

RECOMMENDED CHANGES TO EQUIPMENT TECHNICAL PUBLICATIONS



THEN, JOT DOWN THE DOPE ABOUT IT ON THIS FORM. CAREFULLY TEAR IT OUT, FOLD IT AND DROP IT IN THE MAIL.

SOMETHING WRONG WITH THIS PUBLICATION?

FROM (PRINT YOUR UNIT'S COMPLETE ADDRESS)

DATE SENT

PUBLICATION NUMBER

TM 11-6665-209-40

PUBLICATION DATE

10 Jun 81

PUBLICATION TITLE

BE EXACT PIN-POINT WHERE IT IS

PAGE NO	PARA GRAPH	FIGURE NO	TABLE NO

IN THIS SPACE TELL WHAT IS WRONG AND WHAT SHOULD BE DONE ABOUT IT:

PRINTED NAME (GRADE OR TITLE AND TELEPHONE NUMBER)

SIGN HERE

U.S. GOVERNMENT PRINTING OFFICE: 1979

FILL IN YOUR
UNIT'S ADDRESS

FOLD BACK

DEPARTMENT OF THE ARMY

OFFICIAL BUSINESS
PENALTY FOR PRIVATE USE \$300

POSTAGE AND FEES PAID
DEPARTMENT OF THE ARMY
DOD 314



Commander
US Army Communications and
Electronics Materiel Readiness Command
ATTN: DRSEL-ME-MQ
Fort Monmouth, New Jersey 07703

TEAR ALONG PERFORATED LINE

THE METRIC SYSTEM AND EQUIVALENTS

WEIGHT MEASURE

1 Centimeter = 10 Millimeters = 0.01 Meters = 0.3937 Inches
 1 Meter = 100 Centimeters = 1000 Millimeters = 39.37 Inches
 1 Kilometer = 1000 Meters = 0.621 Miles

WEIGHTS

1 Gram = 0.001 Kilograms = 1000 Milligrams = 0.035 Ounces
 1 Kilogram = 1000 Grams = 2.2 lb.
 1 Metric Ton = 1000 Kilograms = 1 Megagram = 1.1 Short Tons

LIQUID MEASURE

1 Milliliter = 0.001 Liters = 0.0338 Fluid Ounces
 1 Liter = 1000 Milliliters = 33.82 Fluid Ounces

SQUARE MEASURE

1 Sq. Centimeter = 100 Sq. Millimeters = 0.155 Sq. Inches
 1 Sq. Meter = 10,000 Sq. Centimeters = 10.76 Sq. Feet
 1 Sq. Kilometer = 1,000,000 Sq. Meters = 0.386 Sq. Miles

CUBIC MEASURE

1 Cu. Centimeter = 1000 Cu. Millimeters = 0.06 Cu. Inches
 1 Cu. Meter = 1,000,000 Cu. Centimeters = 35.31 Cu. Feet

TEMPERATURE

$5/9(^{\circ}\text{F} - 32) = ^{\circ}\text{C}$
 212° Fahrenheit is equivalent to 100° Celsius
 90° Fahrenheit is equivalent to 32.2° Celsius
 32° Fahrenheit is equivalent to 0° Celsius
 $9/5^{\circ}\text{C} + 32 = ^{\circ}\text{F}$

APPROXIMATE CONVERSION FACTORS

TO CHANGE	TO	MULTIPLY BY
Inches	Centimeters	2.540
Feet	Meters	0.305
Yards	Meters	0.914
Miles	Kilometers	1.609
Square Inches	Square Centimeters	6.451
Square Feet	Square Meters	0.093
Square Yards	Square Meters	0.836
Square Miles	Square Kilometers	2.590
Acres	Square Hectometers	0.405
Cubic Feet	Cubic Meters	0.028
Cubic Yards	Cubic Meters	0.765
Fluid Ounces	Milliliters	29.573
its	Liters	0.473
arts	Liters	0.946
allons	Liters	3.785
Ounces	Grams	28.349
Pounds	Kilograms	0.454
Short Tons	Metric Tons	0.907
Pound-Feet	Newton-Meters	1.356
Pounds per Square Inch	Kilopascals	6.895
Miles per Gallon	Kilometers per Liter	0.425
Miles per Hour	Kilometers per Hour	1.609

TO CHANGE	TO	MULTIPLY BY
Centimeters	Inches	0.394
Meters	Feet	3.280
Meters	Yards	1.094
Kilometers	Miles	0.621
Square Centimeters	Square Inches	0.155
Square Meters	Square Feet	10.764
Square Meters	Square Yards	1.196
Square Kilometers	Square Miles	0.386
Square Hectometers	Acres	2.471
Cubic Meters	Cubic Feet	35.315
Cubic Meters	Cubic Yards	1.308
Milliliters	Fluid Ounces	0.034
Liters	Pints	2.113
Liters	Quarts	1.057
ers	Gallons	0.264
ms	Ounces	0.035
ograms	Pounds	2.205
Metric Tons	Short Tons	1.102
Newton-Meters	Pounds-Feet	0.738
Kilopascals	Pounds per Square Inch	0.145
ometers per Liter	Miles per Gallon	2.354
ometers per Hour	Miles per Hour	0.621

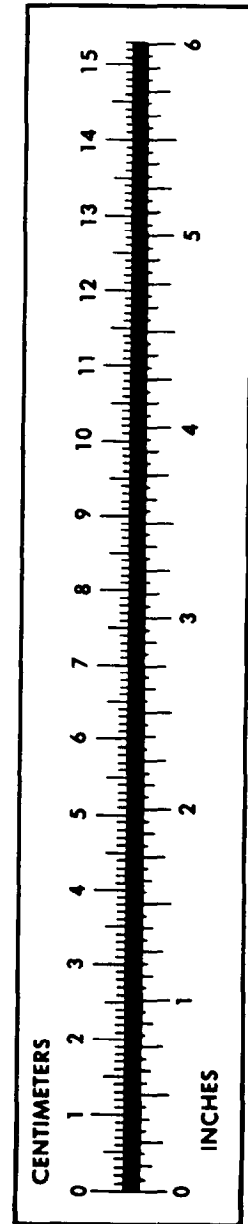

PIN: 049011-000